

## HRLK...-VS series

### Height adjustment castors with adjustment screw, with top plate, with nylon wheel



230–280 kg

**Bracket:** HRLK...-VS series

- strong pressed steel, zinc-plated, blue-passivated, Cr6-free
- double ball bearing in the swivel head
- swivel head seal
- minimum swivel head play and smooth rolling characteristic and increased service life due to the special dynamic Blickle riveting process
- total height can be adjusted when stationary with adjustment screw (SW17), wheel locked in place with adjustment screw is used

**Wheel:** PO series

- high-quality nylon 6, impact resistant, hardness 70 Shore D, colour natural white

**Additional details:**

- bracket series: page 100
- wheel series: page 69
- bearing types: page 84–85

Swivel castors	Wheel Ø (D) [mm]	Wheel width [mm]	Load capacity [kg]	Bearing type	Total height (H) [mm]	Total height max. (h) [mm]	Displacement [mm]	Plate size [mm]	Bolt hole spacing [mm]	Bolt hole Ø [mm]	Offset swivel castor [mm]
HRLK-PO 82G-VS	80	37	230	plain bore	108	120	12	100 x 85	80 x 60	9	42
HRLK-PO 100G-VS	100	37	280	plain bore	128	140	12	100 x 85	80 x 60	9	45

#### Versions / options



	electrically conductive version, non-marking grey	directional lock (separate) 1 x 360°
Technical description page	50	115
<b>Product code suffix</b>	<b>-ELS</b>	<b>RI-05.01</b>
Available for	upon request	all

travelling operation

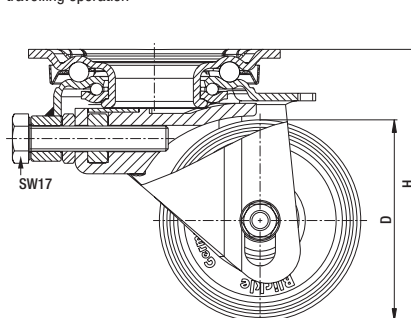

stationary operation

