

## HRLK series

### Levelling castors with fixed operating lever and integrated truck lock, with top plate



170–300 kg

#### Bracket: HRLK series

- strong pressed steel, zinc-plated, blue-passivated, Cr6-free
- double ball bearing in the swivel head
- swivel head seal
- minimum swivel head play and smooth rolling characteristic and increased service life due to the special dynamic Blickle riveting process
- steel truck lock with rubber pad
- height adjustment with lever

#### Wheel:

##### POEV series

- tyre: high-quality elastic solid rubber "Blickle EasyRoll" in smooth rolling quality, hardness 65 Shore A, colour black
- wheel centre: high-quality nylon 6

##### ALST series

- tread: high-quality polyurethane elastomer Blickle Softhane®, hardness 75 Shore A, colour green
- wheel centre: die-cast aluminium

#### ALTH series

- tread: high-quality polyurethane elastomer Blickle Extrathane®, hardness 92 Shore A, colour light brown

- wheel centre: die-cast aluminium

#### PO series

- high-quality nylon 6, impact resistant, hardness 70 Shore D, colour natural white

#### SPO series

- high-quality nylon 6, impact resistant, hardness 70 Shore D, extremely robust heavy-duty version, colour natural white

#### Additional details:

- bracket series: page 99
- wheel series: page 63, 66, 65, 69
- bearing types: page 84–85

Swivel castors	Wheel Ø (D) [mm]	Wheel width [mm]	Load capacity [kg]	Bearing type	Total height (H) [mm]	Total height max. (h) [mm]	Stroke (T4) [mm]	Floor clearance foot max. (T3) [mm]	Plate size [mm]	Bolt hole spacing [mm]	Bolt hole Ø [mm]	Offset swivel castor [mm]
<b>PO series</b>												
HRLK-PO 75G	75	32	200	plain bore	118	120	2	13	100 x 85	80 x 60	9	56
HRLK-PO 82G	80	37	230	plain bore	120	122	2	13	100 x 85	80 x 60	9	56
HRLK-PO 100G	100	37	230	plain bore	140	142	2	13	100 x 85	80 x 60	9	65
HRLK-PO 100KA	100	37	230	ball bearing (C)	140	142	2	13	100 x 85	80 x 60	9	65
<b>SPO series</b>												
HRLK-SPO 75G	75	32	300	plain bore	118	120	2	13	100 x 85	80 x 60	9	56
HRLK-SPO 75K	75	32	300	ball bearing	118	120	2	13	100 x 85	80 x 60	9	56
HRLK-SPO 80K	80	37	300	ball bearing	120	122	2	13	100 x 85	80 x 60	9	56
<b>POEV series</b>												
HRLK-POEV 82KF	80	40	170	ball bearing (C)	120	122	2	13	100 x 85	80 x 60	9	56
HRLK-POEV 100KA	100	32	200	ball bearing (C)	140	142	2	13	100 x 85	80 x 60	9	65
<b>ALST series</b>												
HRLK-ALST 82K	80	40	230	ball bearing	120	122	2	13	100 x 85	80 x 60	9	56
HRLK-ALST 100K	100	40	230	ball bearing	140	142	2	13	100 x 85	80 x 60	9	65
<b>ALTH series</b>												
HRLK-ALTH 80K	80	30	180	ball bearing	120	122	2	13	100 x 85	80 x 60	9	56
HRLK-ALTH 100K	100	40	230	ball bearing	140	142	2	13	100 x 85	80 x 60	9	65

12

#### Versions / options \*

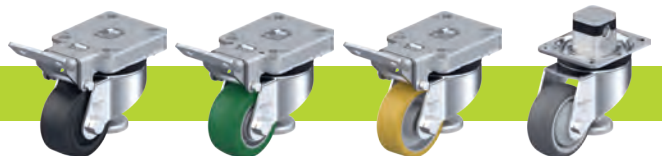
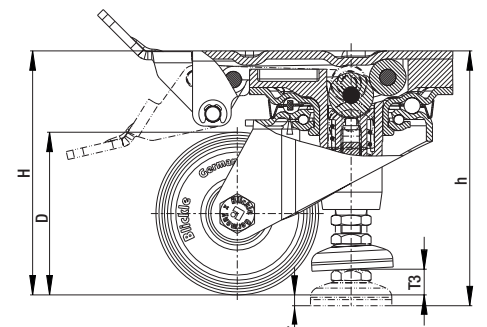

	image POEV series	image ALST series	image ALTH series	with "central-stop" central brake system
Technical description page	63	66	65	113
Product code suffix				-CS13
Available for				upon request



\* Other versions / options: 1. corrosion-resistant version (product code HRLKX-...) upon request 2. electrically conductive version, wheel non-marking grey (product code suffix -EL) PO, SPO series upon request 3. antistatic version, wheel non-marking (product code suffix -AS) ALTH, ALST series upon request 4. synthetic adapter plate (+10 mm) to balance out total height for corresponding swivel and fixed castors: Product code AP1-10