

POEV series (wheel Ø 60–125 mm)

Heavy-duty wheels with elastic solid rubber tyre “Blickle EasyRoll”, with nylon wheel centre

120–250 kg

Tread and tyre hardness

65 Shore A

Smooth operation / floor preservation

very good

Rolling resistance

very good

Wear resistance

good

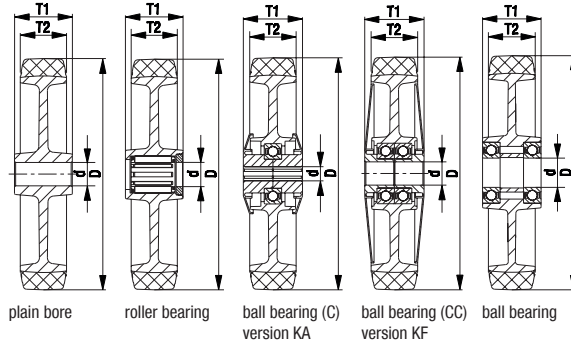

Tyre:

- high-quality elastic solid rubber “Blickle EasyRoll” in smooth rolling quality, hardness 65 Shore A
- very good operational comfort
- very good floor preservation, low-noise operation
- low rolling resistance
- colour black
- vulcanised onto the wheel centre

Wheel centre:

- high-quality nylon 6, impact resistant
- colour black

Other features:

- KA version: with synthetic thread guard, small
- KF version: with synthetic thread guard, large
- high chemical resistance to many aggressive substances, except oils
- operating temperature: -20 °C to +80 °C, temporarily up to +100 °C, reduced load capacity over +35 °C

Additional details:

- wheel series: page 63
- tread: page 53
- bearing types: page 84–85
- chemical resistance: page 51

Wheels	Wheel Ø (D) [mm]	Wheel width (T2) [mm]	Load capacity [kg]	Bearing type	Axle bore Ø (d) [mm]	Hub length (T1) [mm]
POEV 60/8KF	60	34	120	ball bearing (CC)	8	36
POEV 80/12G	80	32	140	plain bore	12	35
POEV 80/12R	80	32	140	roller bearing	12	35
POEV 80/8KF	80	32	140	ball bearing (C)	8	36
POEV 82/8KF	80	40	170	ball bearing (C)	8	46
POEV 82/10KF	80	40	170	ball bearing (C)	10	46
POEV 100/12G	100	32	200	plain bore	12	45
POEV 100/12R	100	32	200	roller bearing	12	45
POEV 100/15R	100	32	200	roller bearing	15	45
POEV 100/8KA	100	32	200	ball bearing (C)	8	46
POEV 100/10KA	100	32	200	ball bearing (C)	10	46
POEV 100/15K	100	32	200	ball bearing	15	45
POEV 125/12G	125	37	250	plain bore	12	45
POEV 125/12R	125	37	250	roller bearing	12	45
POEV 125/15R	125	37	250	roller bearing	15	45
POEV 125/8KA	125	37	250	ball bearing (C)	8	46
POEV 125/10KA	125	37	250	ball bearing (C)	10	46
POEV 125/15K	125	37	250	ball bearing	15	45
POEV 125/20K	125	37	250	ball bearing	20	45

For other wheel Ø, see next page

Versions / options



	with non-marking grey tyre	with non-marking blue tyre	electrically conductive version, black tyre	with stainless steel roller bearing in the wheel hub	small thread guard with additional ball bearing seal	large thread guard with additional ball bearing seals	with stainless steel ball bearing and thread guard
Technical description page	52	53	50	84	85	85	84–85
Product code suffix	-SG	-SB	-EL	-XR	-KAD	-KFD	-XKA / -XKF
Available for	all	wheel Ø 80x32, 100, 125 mm	ball bearing versions upon request	all	all KA versions	all KF versions	all KA- and KF- versions of version -SG*

* With exception of wheel Ø 60 mm